

HA2FM Series Axial Piston Fixed Displacement Motor

Product show and brief introduction

Open and closed circuits

Series 6
Sizes 10...180
Nominal pressure 40MPa
Peak pressure 45MPa



Features

- Fixed displacement motor HA2FM of axial piston, bent axis design, suitable for hydrostatic drives in open and closed circuits
- Use in mobile and industrial applications
- The output speed depends on the flow capacity of the pump and the displacement of the motor
- The torque increases with the pressure differential between the high and low pressure side and with increasing displacement
- Careful selection of the displacements offered, permit sizes to be matched to practically every application
- High power density
- Compact design
- High overall efficiency
- Excellent starting torque efficiency
- Economical conception
- One piece pistons with piston rings

Model Code

HA2F	M	80	/6	1	W	-V	A	B	010
Axial piston unit	Mode of operation	Size (mL/r)	Series	Index	Direction of rotation	Seals	Shaft end	Mounting flange	Service line ports
HA2F: Bent axis design, fixed displacement	M: Motor	10	6	1	(Viewed on shaft end)	V: FKM (fluor~ caoutchouc)	See below	B: 4-hole ISO 3019-2	See below
		12							
		16							
		23							
		28							
		32							
		45							
		56							
		63							
		80							
		90							
		107							
		125							
160									
180									
					W: Alternating				

Shaft end

Size		10	12	16	23	28	32	45	56	63	80	90	107	125	160	180
Spined shaft DIN 5480	A	✓	✓	✓	✓	✓	✓	/	✓	✓	✓	✓	✓	✓	✓	✓
	Z	✓	✓	/	✓	✓	/	✓	✓	/	✓	/	✓	/	✓	/
Parallel keyed shaft, DIN 6885	B	✓	✓	✓	✓	✓	✓	/	✓	✓	✓	✓	✓	✓	✓	✓
	P	✓	✓	/	✓	✓	/	✓	✓	/	✓	/	✓	/	✓	/

Service line port¹⁾

Size	10	12	16	23	28	32	45	56	63	80	90	107	125	160	180
010:SAE flange ports A and B, rear	/	/	/	✓	✓	✓	✓	✓	✓	✓	✓	✓	✓	✓	✓
020:SAE flange ports A and B, at side, opposite	/	/	/	✓	✓	✓	✓	✓	✓	✓	✓	✓	✓	✓	✓
030:Threaded ports A and B, at side, opposite	✓	✓	✓	✓	✓	✓	/	/	/	/	/	/	/	/	/
040:Threaded port A and B, at side and rear ²⁾	✓	✓	✓	✓	✓	✓	✓	✓	✓	✓	/	/	/	/	/

✓ = available / = not available

1) fastening threads resp. threaded ports are metric

2) at side (sizes 10...63) or rear thread ports plugged with locking screw

Technical Data

● Hydraulic fluid

The HA2FM fixed displacement motor is suitable for use with mineral oil.

● Viscosity range

We recommend that a viscosity (at operating temperature) for optimum efficiency and service life purposes of

$$V_{opt} = \text{optimum viscosity } 16 \dots 36 \text{ mm}^2/\text{s}$$

Be chosen, taken the circulation temperature (closed circuit) and tank temperature (open circuit) into account.

● Limits of viscosity range

The following values apply in extreme cases:

$V_{min} = 5 \text{ mm}^2/\text{s}$
short term ($t < 3 \text{ min}$) at max. permitted temperature
 $t_{max} = 115^\circ\text{C}$

$V_{max} = 1600 \text{ mm}^2/\text{s}$
short term ($t < 3 \text{ min}$) with cold start ($P < 3 \text{ MPa}$,
 $n < 1000 \text{ rpm}$, $t_{min} = -40^\circ\text{C}$)

Note that the maximum hydraulic fluid temperature must not be exceeded locally (e.g. bearing area). The temperature in the bearing area is depending on pressure and speed up to 12 K higher than the average case drain temperature.

● Selection diagram

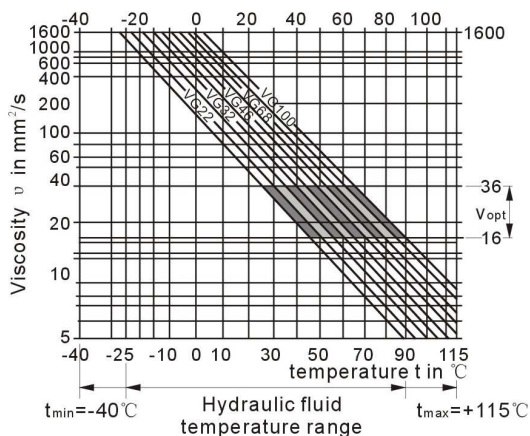

● Details regarding the choice of hydraulic fluid

The correct choice of pressure fluid requires knowledge of the operating temperature in relation to the ambient temperature: in a closed circuit the circulation temperature, in an open circuit the tank temperature.

The hydraulic fluid should be selected so that within the operating temperature range, the operating viscosity lies within the optimum range (V_{opt} ; see shaded section of the selection diagram). We recommend that the highest possible viscosity range should be chosen in each case.

Example: At an ambient temperature of $X^\circ\text{C}$ an operating temperature of 60°C is set in the circuit. In the optimum operating viscosity range (V_{opt} ; shaded area) this corresponds to the viscosity classes VG 46 or VG 68; to be selected: VG 68.

Please note: The leakage fluid temperature, which is affected by pressure and rotational speed, is always higher than the circulation temperature or tank temperature. At no point in the system may the temperature be higher than 115°C .

● Filtration

The finer the filtration, the cleaner the fluid and the longer the service life of the axial piston unit.

To ensure proper function of the axial piston unit, the hydraulic fluid must have a cleanliness level of at least

20/18/15 according to ISO 4406.

At very high hydraulic fluid temperatures (90°C to max. 115°C), a cleanliness level of at least

19/17/14 according to ISO 4406 is required.

Please contact us if these cleanliness levels cannot be achieved.

● Operational pressure range

Maximum pressure on port A or B
(pressure data according to DIN 24312)

	Shaft end A, Z	Shaft end B, P
Nominal pressure P_N	40 MPa	35 MPa
Peak pressure P_{max}	45 MPa	40 MPa
summation pressure (A+B)	70 MPa	70 MPa

Please note: at the shaft end Z and P, a nominal pressure of $P_N = 31.5 \text{ MPa}$ ($P_{max} = 35 \text{ MPa}$) is permitted for the driven shaft end that is subjected to transverse bending (pinions, V-belts)!

Size 56 with shaft end Z: $P_N = 35 \text{ MPa}$, $P_{max} = 40 \text{ MPa}$

in cases of pulsating loading above 31.5 MPa, we recommend the version with splined shaft A or splined shaft Z (sizes 45)

● Direction of flow

Direction of rotation, viewed on shaft end

clockwise	counter-clockwise
A to B	B to A

● Speed range

No limit to minimum speed n_{min} . If uniform motion is required, n_{min} must not be less than 50 rpm.

● Shaft seal ring

Permissible pressure load

The service life of the shaft seal ring is affected by the speed of the motor and the case drain pressure. The permitted loading with intermittent case drain pressure depends on the rotational speed (see chart). Short-term ($t < 5 \text{ min}$) pressure spikes of up to 1 MPa absolute are permitted.

The average permanent case drain pressure must not exceed 0.3 MPa absolute.

The pressure in the case must be equal to or greater than the external pressure on the shaft seal.

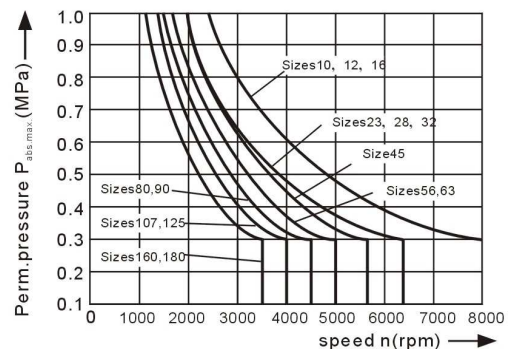

● Temperature range

The FKM shaft seal is admissible for a housing temperature range from -25°C to $+115^\circ\text{C}$

Technical Data

- Table of values (theoretical values, ignoring η_{\min} and η_v ; values rounded)

Size			10	12	16	23	28	32	45	
Displacement	V_g	mL/r	10.3	12.0	16.0	22.9	28.1	32.0	45.6	
Speed max	n_{\max}	min ⁻¹	8000	8000	8000	6300	6300	6300	5600	
	$n_{\max \text{ limit}}^{1)}$	min ⁻¹	8800	8800	8800	6900	6900	6900	6200	
Flow max.	$q_{v\max}$	L/min	82	96	128	144	176	201	255	
Torque constants	T_k	Nm/MPa	1.64	1.9	2.5	3.6	4.45	5.09	7.25	
Torque at	$\Delta P=35 \text{ MPa}$	T	Nm	57	67	88	126	156	178	254
	$\Delta P=40 \text{ MPa}$	T	Nm	65	76	100	144	178	204	290
Filling capacity		L	0.17	0.17	0.17	0.20	0.20	0.20	0.33	
Mass moment of inertia around output shaft	J	kgm ²	0.0004	0.0004	0.0004	0.0012	0.0012	0.0012	0.0024	
Mass(approx.)		kg	5.4	5.4	5.4	9.5	9.5	9.5	13.5	

Size			56	63	80	90	107	125	160	180	
Displacement	V_g	mL/r	56.1	63.0	80.4	90.0	106.7	125.0	160.4	180.0	
Speed max	n_{\max}	min ⁻¹	5000	5000	4500	4500	4000	4000	3600	3600	
	$n_{\max \text{ limit}}^{1)}$	min ⁻¹	5500	5500	5000	5000	4400	4400	4000	4000	
Flow max.	$q_{v\max}$	L/min	280	315	360	405	427	500	577	648	
Torque constants	T_k	Nm/MPa	8.9	10.0	12.7	17.0	19.9	25.4	28.6	31.8	
Torque at	$\Delta P=35 \text{ MPa}$	T	Nm	312	350	445	501	595	697	889	1001
	$\Delta P=40 \text{ MPa}$	T	Nm	356	400	508	572	680	796	1016	1144
Filling capacity		L	0.45	0.45	0.55	0.55	0.8	0.8	1.1	1.1	
Mass moment of inertia around output shaft	J	kgm ²	0.0042	0.0042	0.0072	0.0072	0.0116	0.0116	0.0220	0.0220	
Mass(approx.)		kg	18	18	23	23	32	32	45	45	

1) intermittent maximum speed: overspeed at discharge and over-running travel operations, $t < 5 \text{ sec.}$ and $\Delta P < 15 \text{ MPa.}$



- Determining the size



Flow	$q_v = \frac{V_g \cdot n}{1000 \cdot \eta_v}$	[L/min]	$V_g = \text{Displacement per revolution in mL/r}$
Speed	$n = \frac{q_v \cdot 1000 \cdot \eta_v}{V_g}$	[rpm]	$\Delta P = \text{Differential pressure in MPa}$
Torque	$T = \frac{V_g \cdot \Delta P \cdot \eta_{mh}}{20 \pi}$	[Nm]	$n = \text{Speed in rpm}$
Power	$P = \frac{2 \pi \cdot T \cdot n}{60000} = \frac{q_v \cdot \Delta P}{600 \cdot \eta_t}$	[kW]	$\eta_v = \text{Volumetric efficiency}$
			$\eta_{mh} = \text{Mechanical-hydraulic efficiency}$
			$\eta_t = \text{Overall efficiency}$

Technical Data

● Permissible radial and axial loading on the drive shaft

The values given are maximum values and do not apply to continuous operation

Size	10	12	16	23	28	32	45	56				
Radial force, max. ¹⁾ at distance a (from shaft collar)			$F_{q\ max}$	N	2350	2750	3700	4300	5400	6100	8150 ²⁾	9200 ²⁾
	a		mm		16	16	16	16	16	16	18	18
Axial force, max. ³⁾			$+ F_{ax\ max}$	N	320	320	320	500	500	500	630	800
			$- F_{ax\ max}$	N	320	320	320	500	500	500	630	800
Permissible axial force/MPa operating pressure	$\pm F_{ax\ per}/MPa$		N/MPa		30	30	30	52	52	52	70	87

Size	63	80	90	107	125	160	180				
Radial force, max. ¹⁾ at distance a (from shaft collar)			$F_{q\ max}$	N	10300	11500 ²⁾	12900	13600	15900	18400	20600
	a		mm		18	20	20	20	20	25	25
Axial force, max. ³⁾			$+ F_{ax\ max}$	N	800	1000	1000	12500	1250	1600	1600
			$- F_{ax\ max}$	N	800	1000	1000	12500	1250	1600	1600
Permissible axial force/MPa operating pressure	$\pm F_{ax\ per}/MPa$		N/MPa		87	106	106	129	129	167	167

1) during intermittent operation

2) permissible max. radial force with shaft end Z: $F_{q\ max} = 6500N$

3) max. permissible axial force when stopped or when axial piston unit working in pressureless conditions

4) when stopped or when axial piston unit working in pressureless conditions. Higher forces are permitted when under pressure.
Please contact us.

When considering the permissible axial force, the force-transfer direction must be taken into account:

- $F_{ax\ max}$ = increase in service life of bearings

+ $F_{ax\ max}$ = reduction in service life of bearings (avoid if at all possible)

● Minimum inlet pressure on service line port A(B)

In order to avoid damage of the motor a minimum inlet pressure at the inlet zone must be assured.

The minimum inlet pressure is related to the rotational speed of the fixed motor.

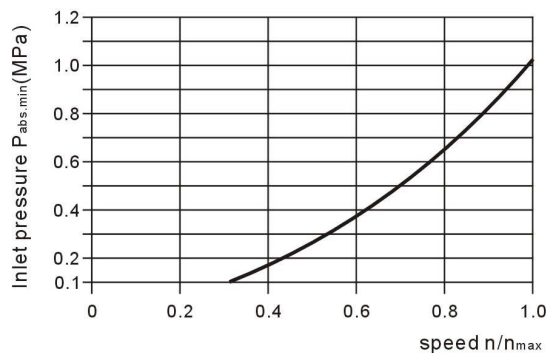

Please contact us if these conditions cannot be satisfied.

Installation dimensions

HA2FM10/61W-V*B*
 HA2FM12/61W-V*B*
 HA2FM16/61W-V*B*

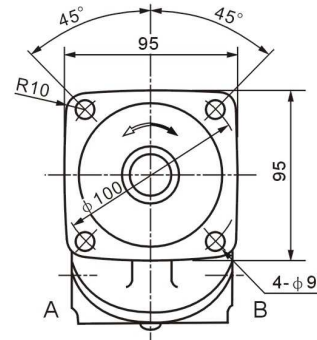
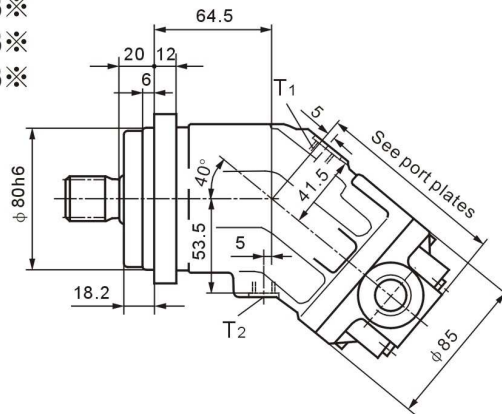

Ports

A, B Service line ports (see port plates)
 T₁, T₂ Case drain ports (T₁ plugged) M12×1.5

Port plates

03 Threaded ports, at side

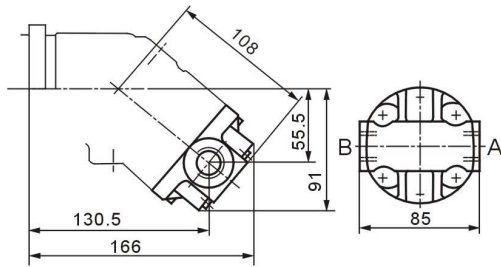

A, B Service line ports

M22×1.5

03 Threaded ports, at side and rear

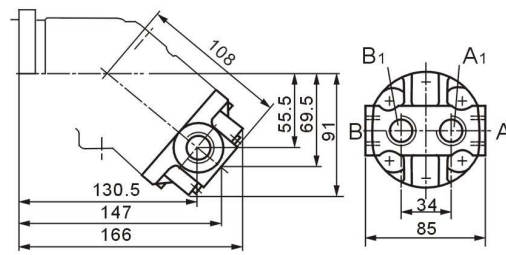

A, B, A₁, B₁ Service line ports

M22×1.5

Shaft ends

Sizes 10, 12, 16
 A Splined shaft DIN 5480
 W25×1.25×30×18×9g
 P_N = 40 MPa

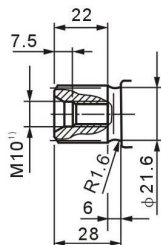

Sizes 10, 12
 Z Splined shaft DIN 5480
 W20×1.25×30×14×9g
 P_N = 40 MPa

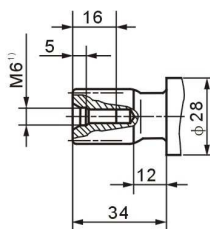

Sizes 10, 12, 16
 B Parallel keyed shaft,
 DIN 6885, AS8×7×32
 P_N = 35 MPa

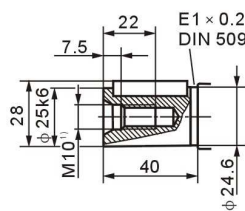

Sizes 10, 12
 P Parallel keyed shaft
 DIN 6885, A6×6×32
 P_N = 35 MPa

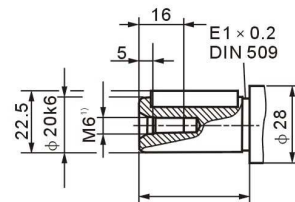

1) centering bore according to DIN 332 (thread according to DIN 13)

Installation dimensions

Shaft ends

Sizes 23,28,32
A Splined shaft DIN 5480
W30×2×30×14×9g
P_N = 40 MPa

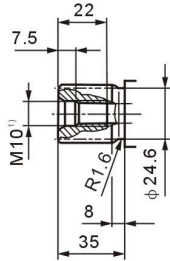

Sizes 23,28
Z Splined shaft DIN 5480
W25×1.25×30×18×9g
P_N = 40 MPa

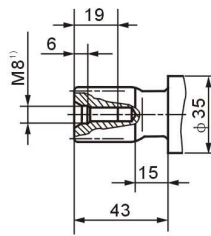

Sizes 23,28,32
B Parallel keyed shaft,
DIN 6885, AS8×7×40
P_N = 35 MPa

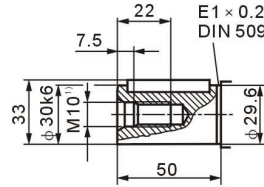

Sizes 23,28
P Parallel keyed shaft
DIN 6885, AS8×7×40
P_N = 35 MPa

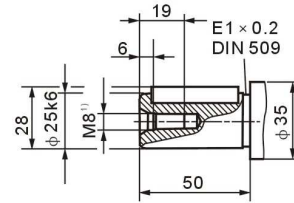

1) centering bore according to DIN 332 (thread according to DIN 13)

Installation dimensions

HA2FM45/61W-V*B*

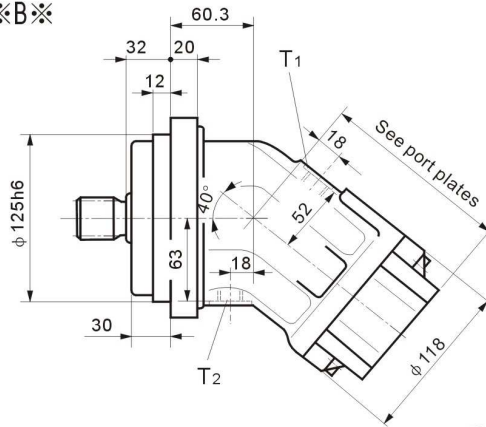

Ports

A, B Service line ports (see port plates)
 T₁, T₂ Case drain ports (T₁ plugged) M18×1.5

Port plates

01 SAE flange ports, rear

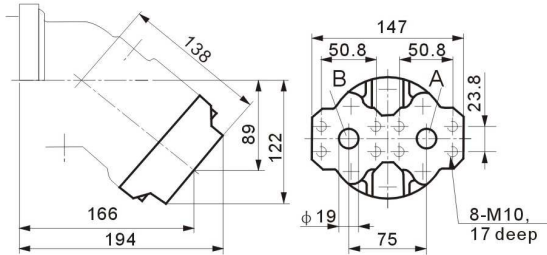

A, B Service line ports SAE 3/4"
 42 MPa (6000 psi) high pressure series

02 SAE flange ports, at side

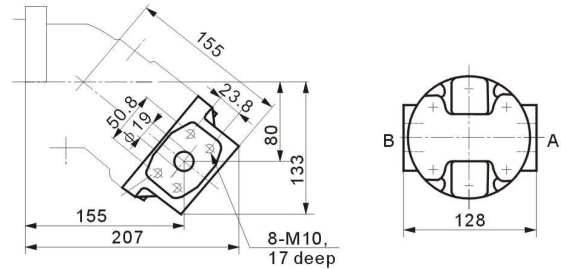

A, B Service line ports SAE 3/4"
 42 MPa (6000 psi) high pressure series

04 Threaded ports, at side and rear

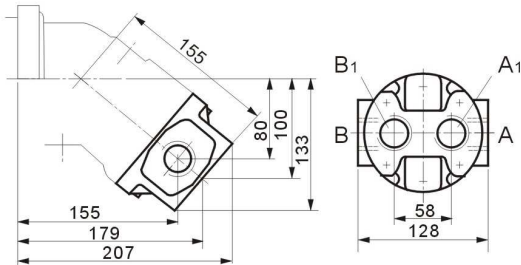

A, B, A₁, B₁ Service line ports M33×2

Shaft ends

Size 45
 Z Splined shaft DIN 5480
 W30×2×30×14×9g
 P_N = 40 MPa

Size 45
 P Parallel keyed shaft
 DIN 6885, AS8×7×50
 P_N = 35 MPa

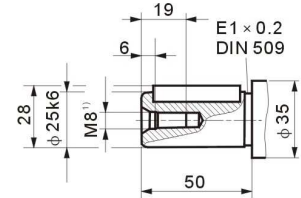
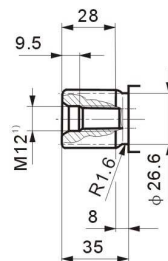

1) centering bore according to DIN 332
 (thread according to DIN 13)

Installation dimensions

Shaft ends

Sizes 56,63
A Splined shaft DIN 5480
 W35×2×30×16×9g
 P_N = 40 MPa

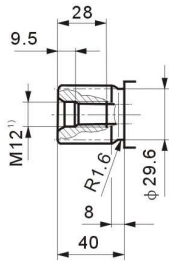

Sizes 56
Z Splined shaft DIN 5480
 W30×2×30×14×9g
 P_N = 35 MPa

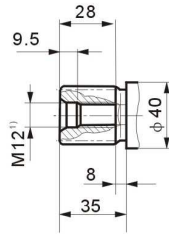

Sizes 56,63
B Parallel keyed shaft,
 DIN 6885, AS10×8×50
 P_N = 35 MPa

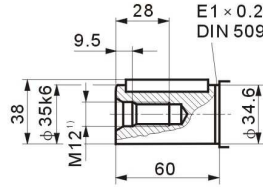

Size 56
P Parallel keyed shaft
 DIN 6885, AS8×7×50
 P_N = 35 MPa

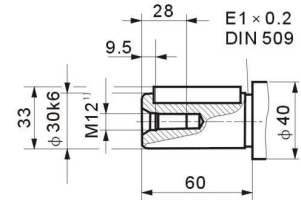

1) centering bore according to DIN 332 (thread according to DIN 13)

Installation dimensions

HA2FM80/61W-V***B***
HA2FM90/61W-V***B***

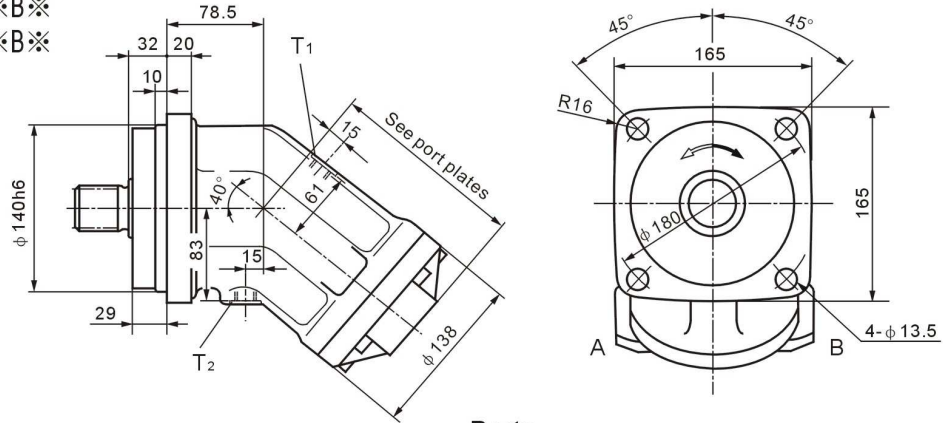

Ports

A, B Service line ports (see port plates)
T₁, T₂ Case drain ports (T₁ plugged) M18×1.5

Port plates

01 SAE flange ports, rear

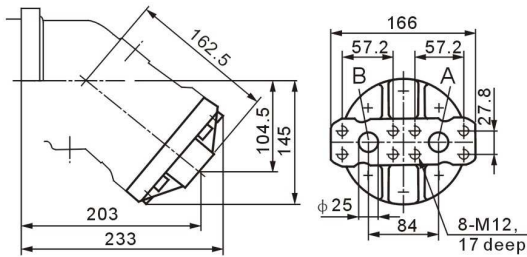

A, B Service line ports
42 MPa (6000 psi) high pressure series
SAE 1"

02 SAE flange ports, at side

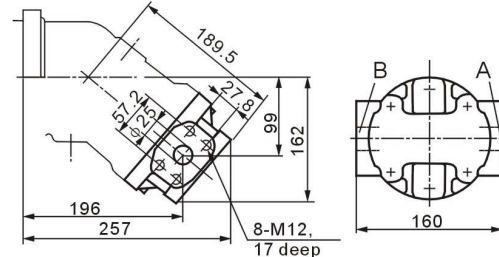

A, B Service line ports
42 MPa (6000 psi) high pressure series
SAE 1"

Shaft ends

Sizes 80, 90
A Splined shaft DIN 5480
W40×2×30×18×9g
P_N = 40 MPa

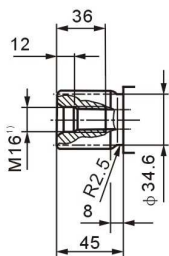

Size 80
Z Splined shaft DIN 5480
W35×2×30×16×9g
P_N = 40 MPa

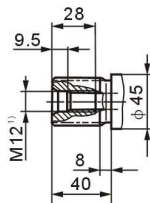

Sizes 80, 90
B Parallel keyed shaft,
DIN 6885, AS12×8×56
P_N = 35 MPa

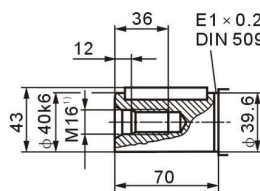

Size 80
P Parallel keyed shaft
DIN 6885, AS10×8×56
P_N = 35 MPa

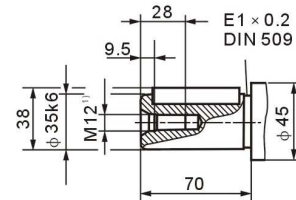

1) centering bore according to DIN 332 (thread according to DIN 13)

Installation dimensions

HA2FM107/61W-V*B*
HA2FM125/61W-V*B*

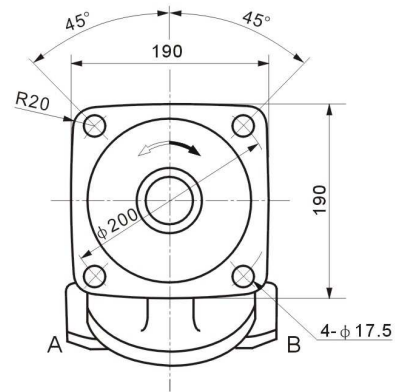
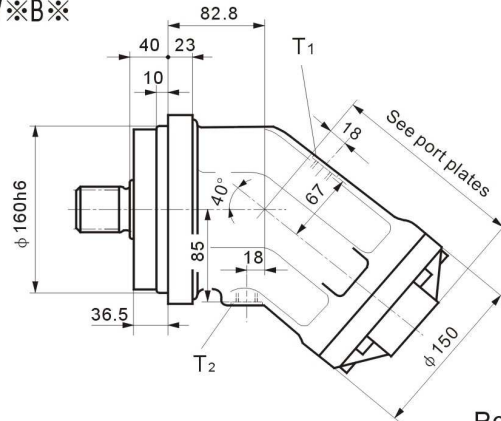

Ports

A,B Service line ports (see port plates)
T,T₂ Case drain ports (T₁ plugged) M18×1.5

Port plates

01 SAE flange ports, rear

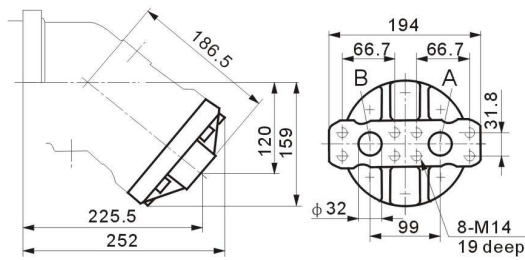

A,B Service line ports
42 MPa (6000 psi) high pressure series
SAE 1 1/4"

02 SAE flange ports, at side
(dimensions for size 107 in bracket)

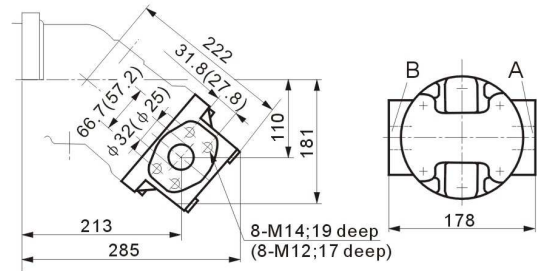

A,B Service line ports
42 MPa (6000 psi) high pressure series
SAE 1 1/4" (1")

Shaft ends

Sizes 107, 125
A Splined shaft DIN 5480
W45×2×30×21×9g
P_N = 40 MPa

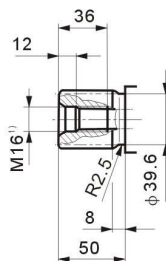

Size 107
Z Splined shaft DIN 5480
W40×2×30×18×9g
P_N = 40 MPa

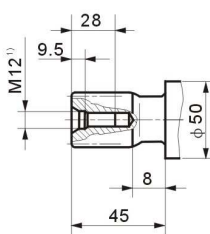

Sizes 107, 125
B Parallel keyed shaft,
DIN 6885, AS14×9×63
P_N = 35 MPa

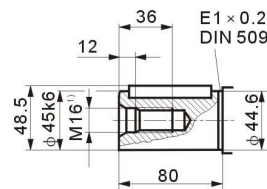

Size 107
P Parallel keyed shaft
DIN 6885, AS12×8×63
P_N = 35 MPa

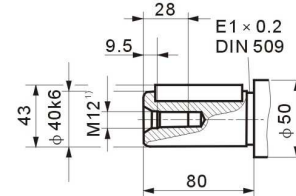

1) centering bore according to DIN 332 (thread according to DIN 13)

Installation dimensions

HA2FM160/61W-V***B***
HA2FM180/61W-V***B***

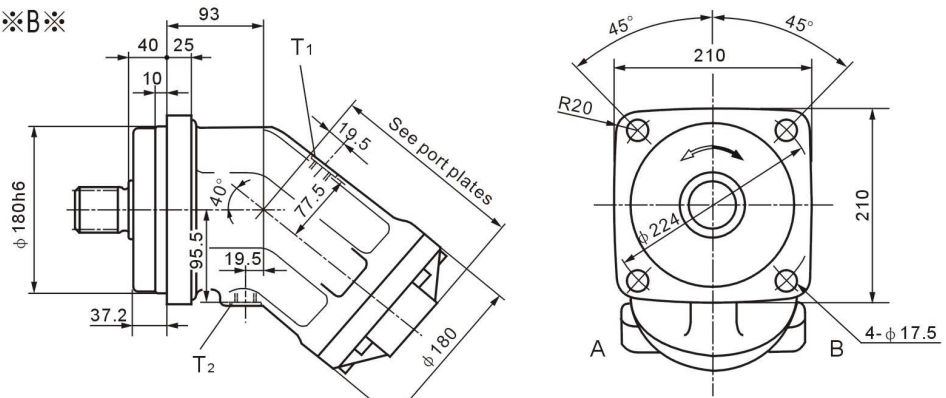

Ports

A,B Service line ports (see port plates)
T,T₂ Case drain ports (T₁ plugged) M22×1.5

Port plates

01 SAE flange ports, rear

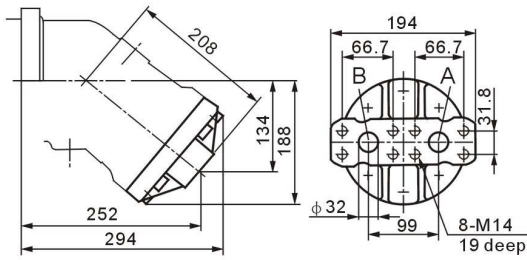

A,B Service line ports
42 MPa(6000 psi)high pressure series
SAE 1 1/4"

02 SAE flange ports, at side

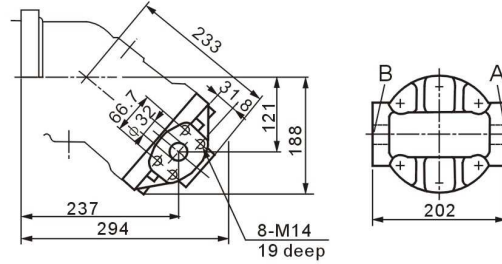

A,B Service line ports
42 MPa(6000 psi)high pressure series
SAE 1 1/4"

Shaft ends

Sizes 160,180
A Splined shaft DIN 5480
W50×2×30×24×9g
PN = 40 MPa

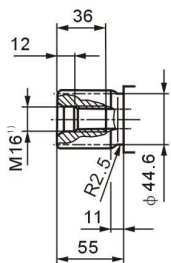

Size 160
A Splined shaft DIN 5480
W45×2×30×21×9g
PN = 40 MPa

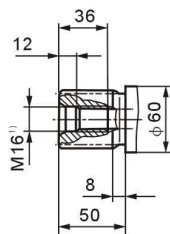

Sizes 160,180
P Parallel keyed shaft
DIN 6885, AS14×9×70
PN = 35 MPa

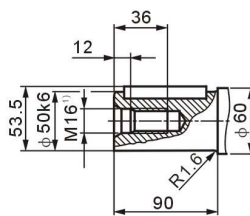

Size 160
P Parallel keyed shaft
DIN 6885, AS14×9×70
PN = 35 MPa

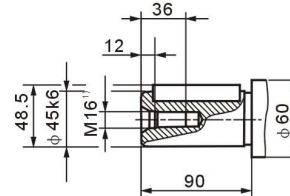

1) centering bore according to DIN 332 (thread according to DIN 13)

Installation and Commissioning Notes

● General

The motor case must be completely filled up with hydraulic fluid during startup and during operation (filling the case chamber). The motor must be started up at low speed and no load until the system has been bled completely.

If stopped for an extended period, fluid may drain out of the case through the service lines. When restarting, make sure that the case contains sufficient fluid.

The leakage fluid inside the case chamber must be drained off to the tank through the highest case drain port.

● Installation position

Optional. With installation position "shaft to the top" use motor with bleeding port R.

● Installation below the tank

Motor below min. fluid level in the tank (standard)

- Fill axial piston motor before startup via the highest case drain port
- Run the motor at low speed until the system is bled completely (bleed through service line port A, B if tubing is long)
- Minimum immersion depth of leakage line in tank: 200mm (relative to the min. fluid level in the tank).
- Additional measures required for installation position 2 (shaft facing up); with installation position 2, make sure that the motor case is completely full before starting up. Bleed at port R.
Order port R in clear text. An air pocket in the bearing area is leading to damage of the axial piston motor.

● Installation above the tank

Motor above min. fluid level in tank

- Proceed in same way as below the tank installation
- Additional measures for installation position 1 and 2: If stopped for an extended period, fluid may drain out of the case chamber through the service lines (air enters through the shaft seal). The bearing will therefore not be properly lubricated when the motor is started up again. Fill the axial piston motor before restarting via the highest case drain port. Installation position 2: bleed at port R. Order port R in clear text
- Additional measures required for installation position 2 (shaft facing up):
In this installation position the bearings will not be properly lubricated, even if there is still some fluid in the case chamber. Putting a non-return valve (opening pressure 0.05 MPa) in the leakage line can prevent the system emptying through the line.

