

# DB/DBW DB/DBW 30/5X SERIES PILOT OPERATED PRESSURE RELIEF VALVES

DB is pilot operated pressure relief valve, DBW is a pilot operated solenoid relief valve available to unload system pressure.

The performance of 5X series is superior than 30 series, the 5X series can be used to control the pressure of hydraulic systems smoothly in a wide range. This type is suitable for a hydraulic system which demands high flow rate.

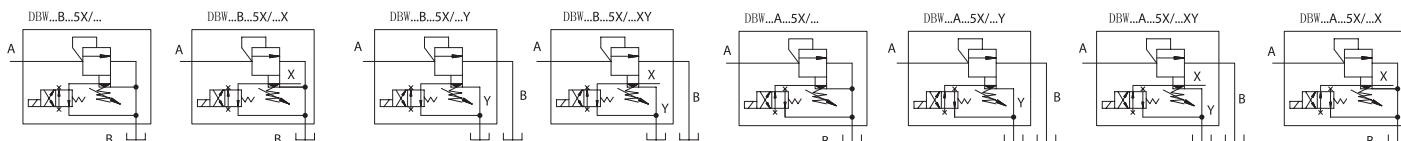

**DB W 10 A G - 1 - 30 / 315 U G24 N Z4 / 2 / V**

<p><b>Model</b></p> <p>No code=Without directional valve W=With directional valve</p> <p>Subplate mounting: 10; 20; 30 Threaded connection: 8; 10; 16; 20; 25; 30</p> <p>A=Normally closed; B=Normally open</p> <p>No code=subplate mounting G=Threaded connection</p> <p>1=Adjustable knob 2=Adjustable hexagonal nut screw and protection cap 3=Lockable rotary knob</p> <p>Series number: 30 Series number 30 and 50</p>	<p>No code=NBR Seals for petroleum oils V=FPM Seals for phosphate ester</p> <p>No code=Inch thread; 2=Metric thread</p> <p>Z4=Quadrate plug; Z5=Big quadrate plug Z5L=Big quadrate plug with light</p> <p>No Code=Without manual override N=With manual override</p> <p>W220=AC 220V; G24=DC 24V</p> <p>No Code=Standard U=For min. opening pressure</p>
---	--

See the table below for pressure range

### Technical data

Size	10		20		30	
	30	5X	30	5X	30	5X
Series No.	30	5X	30	5X	30	5X
Operating pressure(MPa)	31.5	35	31.5	35	31.5	35
Max. flow rate (L/min.)	200	250	400	500	600	650
Fluid temperature (°C)	-20~70					
Filtration accuracy (um)	25					



Operating pressure vs. flow

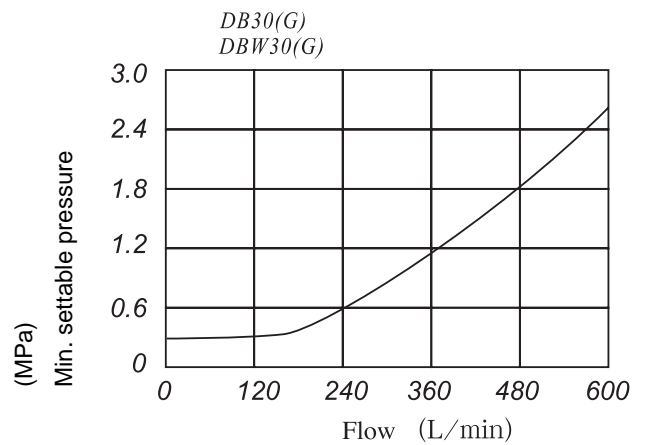
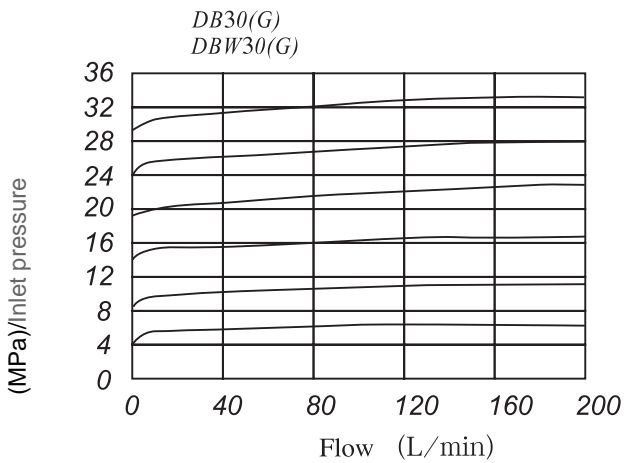
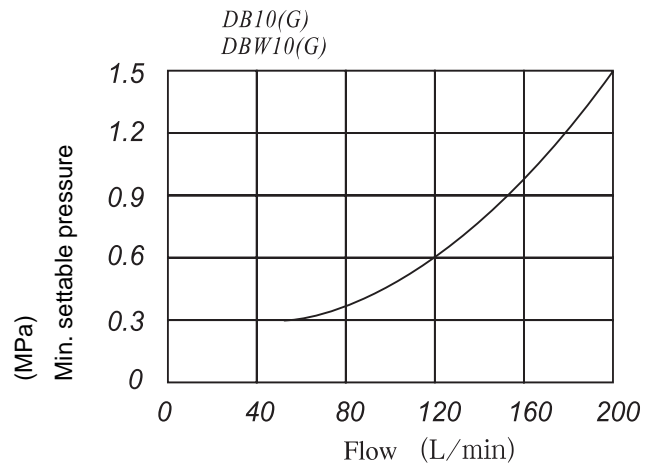
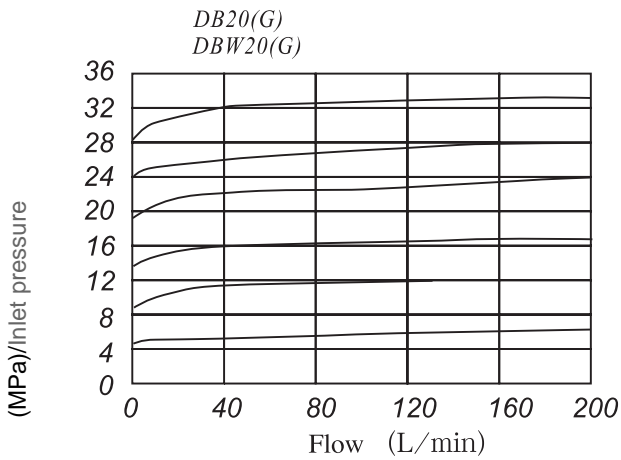
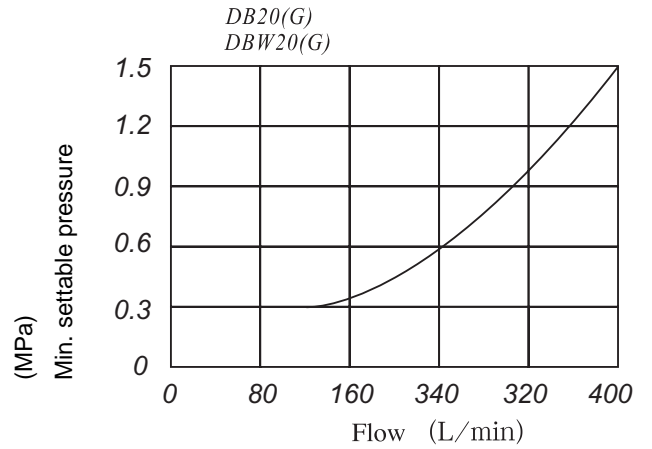
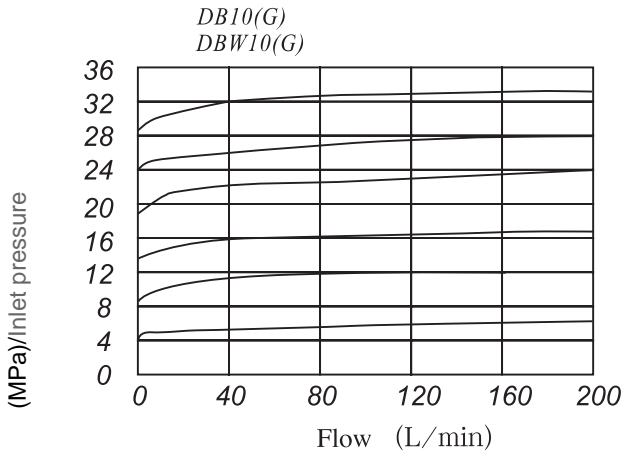

# DB...5X...



Operating curves vs. flow

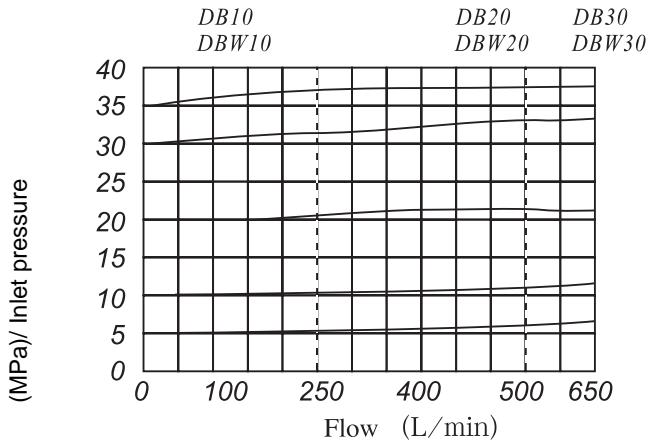

Subplate mounting

DB 10

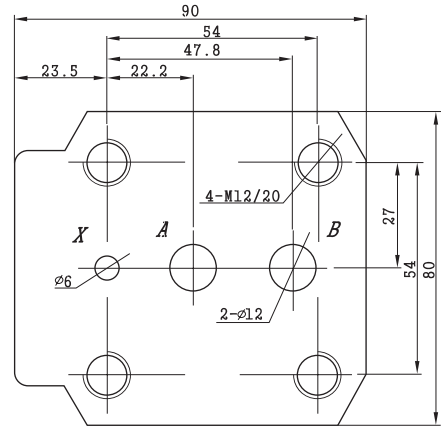

DB 20

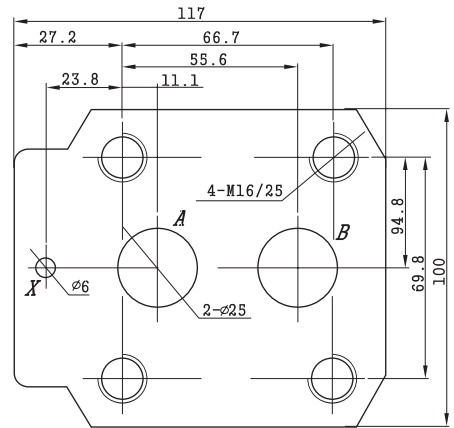

DB 30

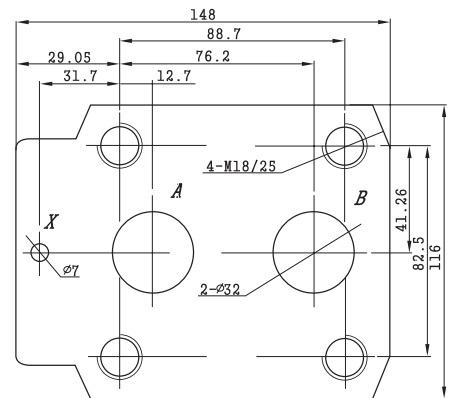

Min. settable pressure and bypass pressure

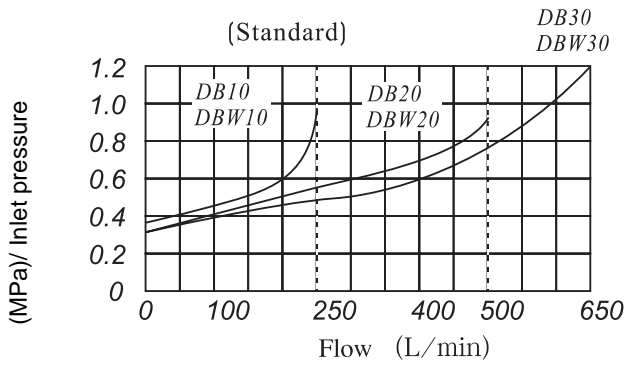

Min. settable pressure and bypass pressure

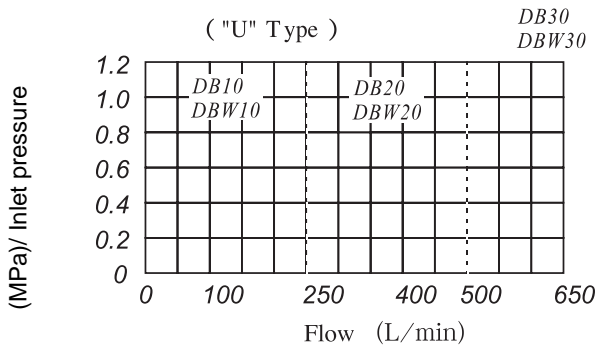



## Threaded Connections

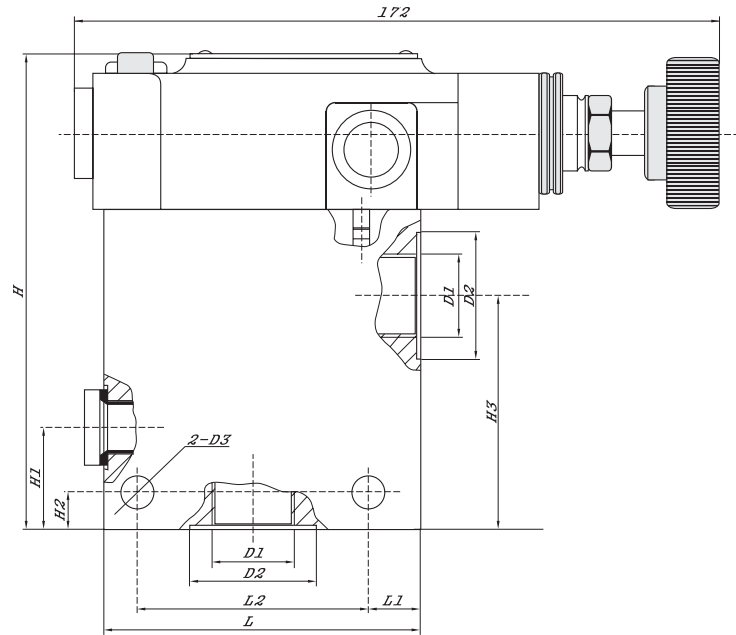

Model	D1		D2	D3	L	L1	L2	H	H1	H2	H3
	Metric	Inch									
DB8G	M18X1.5	G 3/8"	28								
DB10G	M22X1.5	G 1/2"	34								
DB15G	M27X2	G 3/4"	42								62
DB20G	M33X2	G 1"	47	9	85	14	62	125	27	10	57
DB25G	M42X2	G1 1/4"	58								
DB30G	M48X2	G1 1/2"	65	11	100	18	72	138	42	13	66