

# WEH SERIES SOLENOID PILOT OPERATED DIRECTIONAL VALVES

WEH series are solenoid pilot operated spool type valves. This series are used to control the start, stop and direction of flow.



4WEH 10 H E 50 / O G24 N ET S Z4 / B0.8 P4.5 D1 V \*

Size 10; 16; 25; 32

No code=Spring return  
H=Hydraulic return

See the function symbol of spool valve

Series 20=Size 10; Series 50=Size16-32

O=Without spring return  
OF=Without spring return, with detent

G24=DC 24V; W220=AC220V; W110=AC110V

No code=Without manual overrides  
N=With manual overrides

No code=Externally pilot , externally drained  
E=Internally pilot, externally drained  
ET= Internally pilot, internally drained  
T= Externally pilot, internally drained

Technical data

Size		10	16	25	32
Max. operating pressure P. A. B.		28	28	28	28
T (Port) MPa	Externally drained	31,5	25	25	25
	Internally drained	AC -10 DC -16	AC -10 DC -16	AC -10 DC -16	AC -10 DC -16
Y (Port) MPa	Externally drained	AC -10 DC -16	AC -10 DC -16	AC -10 DC -16	AC -10 DC -16
	Min. pilot pressure (MPa)	0.45-1	0.45-1.3	0.45-1	0.45-1
Max. flow rate (L/min.)		160	300	650	1100

For further details

No code=NBR seals for petroleum oils  
V=Phosphate ester

No code=Without ratio pressure reducing valve  
D1=With ratio pressure reducing valve

No code=Without pilot pressure  
P0.45=With pilot pressure  
cracking pressure is 0.45MPa

Omit if without plug-in throttleer  
B0.8=Throttle orifice size 0.8  
B10=Throttle orifice size 1.0  
B12=Throttle orifice size 1.2  
B15=Throttle orifice size 1.5

Z4=Quadrate plug Z5=Large quadrate plug

No code=Without pilot adjustment  
S=With meter-in pilot adjustment  
S1=With meter-out pilot adjustment

# Spool symbols

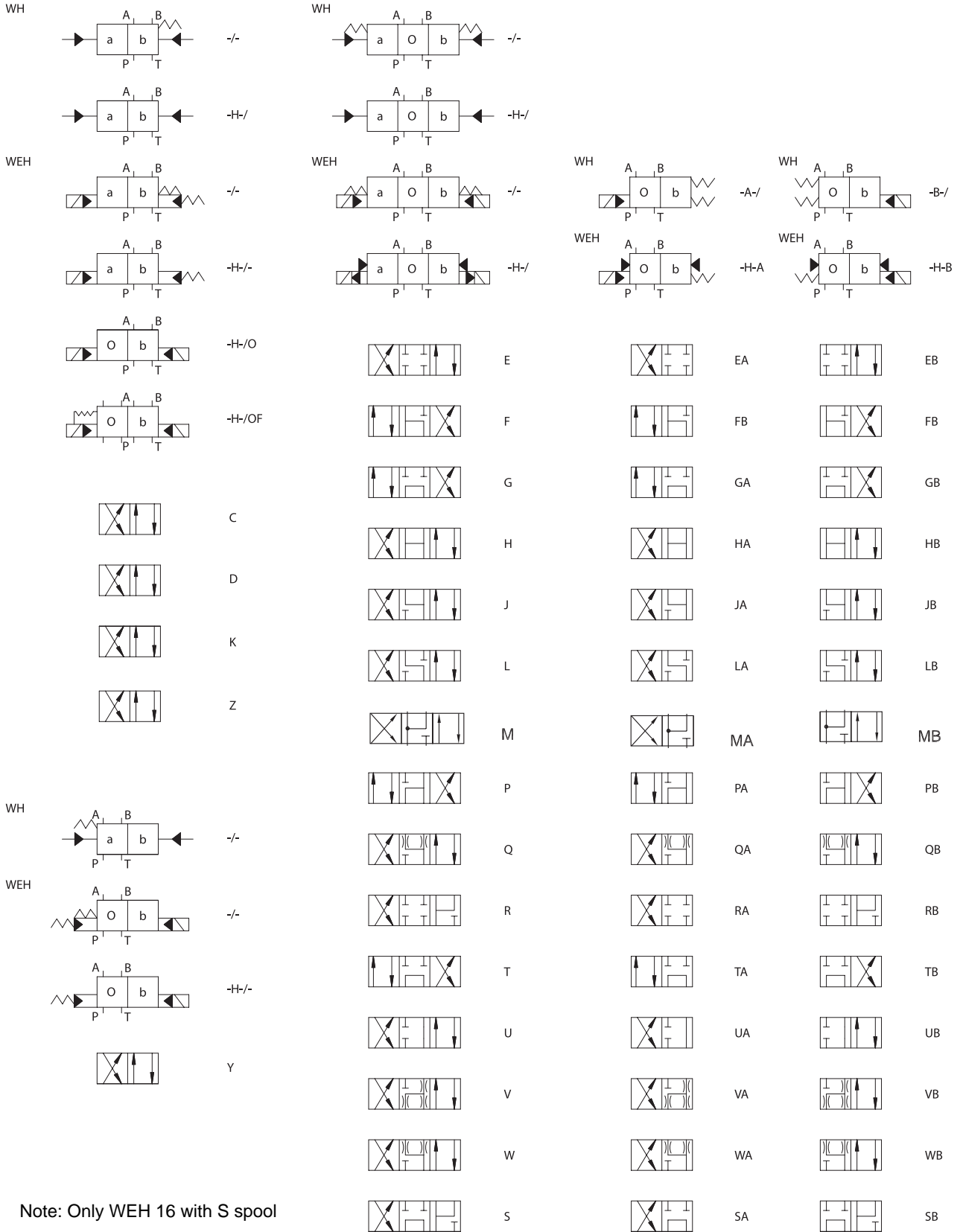

 Pilot fluid supply

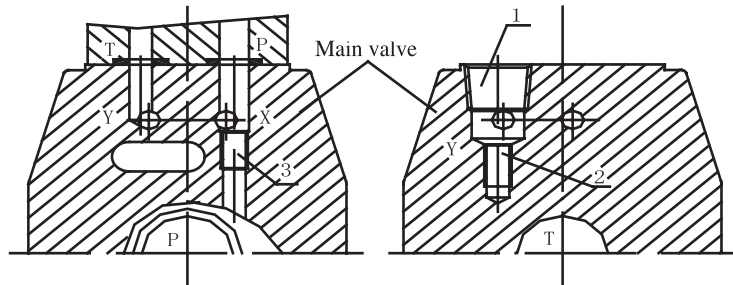

WEH10 explanation partial drawing

WEH 10

1. Internal pilot and external pilot: The "P" port with M6 screw (3) is external pilot, to convert valve into internal pilot, the M6 screw (3) must be removed.
2. Internal drain and external drain: Removing the bolt (1), to install M6 screw (2) is external drain.

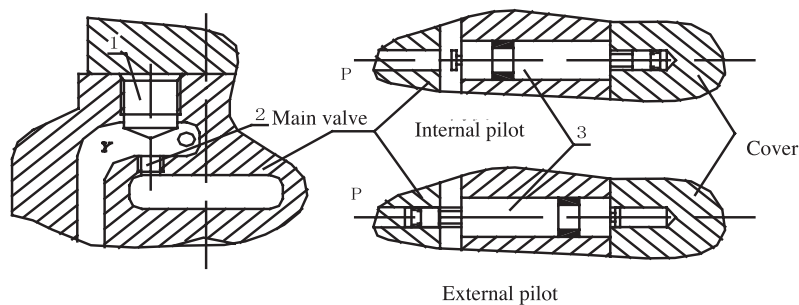

WEH16 explanation partial drawing

WEH16

1. Internal pilot and external pilot: Removing the sideward cover, installing the pin to allow "P" port with open position is internal pilot, to convert the pin into "P" port with plugged position is external drain.
2. Internal drain and external drain: Removing the bolt (1) and installing M6 screw (2) is external drain, unscrew the M6 screw (2) is internal drain.

Pilot fluid supply

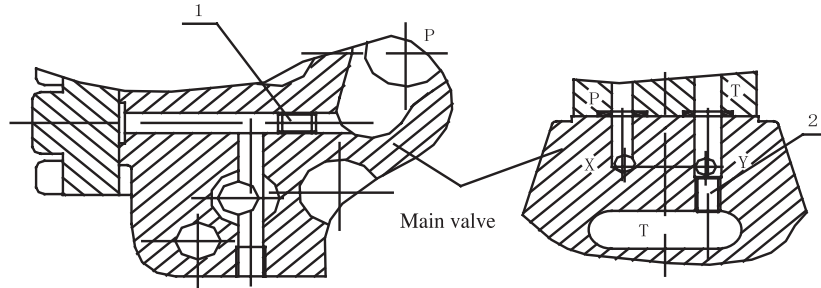

WEH25

WEH25 explanation partial drawing

1. Internal pilot and external pilot

Removing the sideward cover, installing M6 screw (1) is external pilot, unscrew the M6 screw (2) is internal pilot.

2. Internal drain and external drain

Removing the M6 screw (2) in the "T" port on the top of main valve is internal drain; installing the M6 screw (2) is external drain.

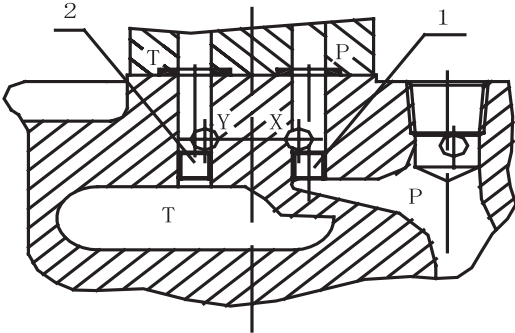

WEH32 explanation partial drawing

WEH32

1. Internal pilot and external pilot

Installing the M6 screw (1) in the "P" port on the top of main valve is external pilot; removing the M6 screw (1) is internal pilot.

2. Internal drain and external drain

Removing the M6 screw (2) in the "T" port on the top of main valve is external drain; installing the M6 screw (2) is internal drain.

**NOTE:** 1. The "X" port on the base plate must be plugged if internal pilot.  
2. The "Y" port on the base plate must be plugged if internal drain.

**Pressure drop vs. flow curves**

WEH 10

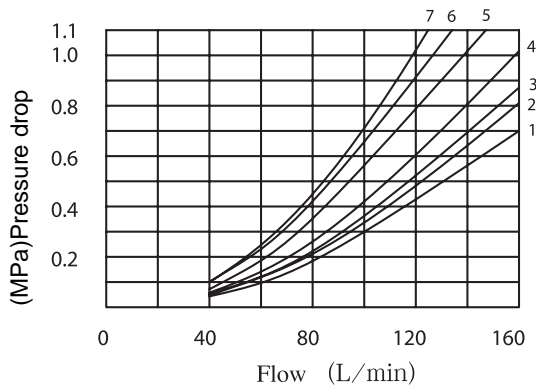

Spool symbols	Middle		
	A-T	B-T	P-T
F	3		6
G			7
H	1	3	5
P		7	5
T			7
L	3		

Spool symbols	Flow direction			
	P-A	P-B	A-T	B-T
E	1	2	4	5
F	1	4	1	4
G	4	2	2	6
H	4	4	1	4
J	1	2	1	3
L	2	3	1	4
M	4	4	3	4
P	4	1	3	4
Q	2	2	3	5
R	2	3	3	5
T	4	2	2	6
U	3	3	3	4
V	2	2	3	5
W	2	2	3	5

WEH 16

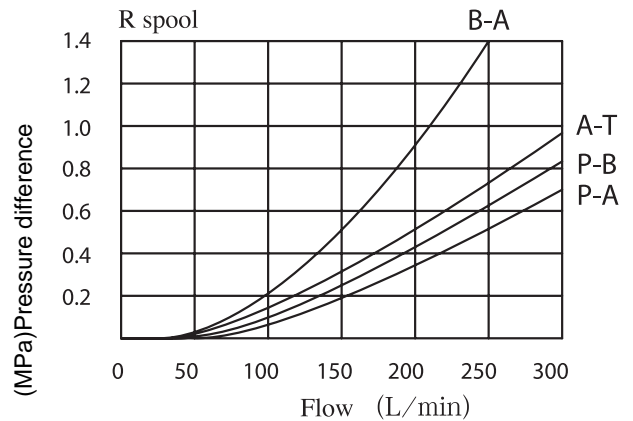
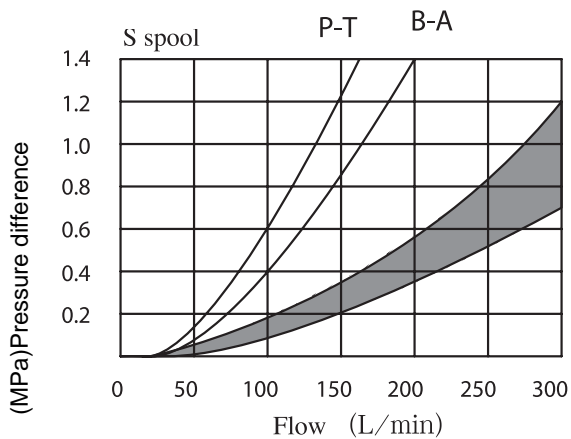
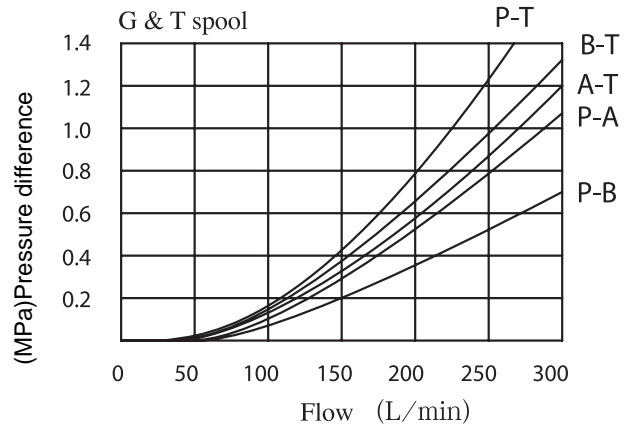
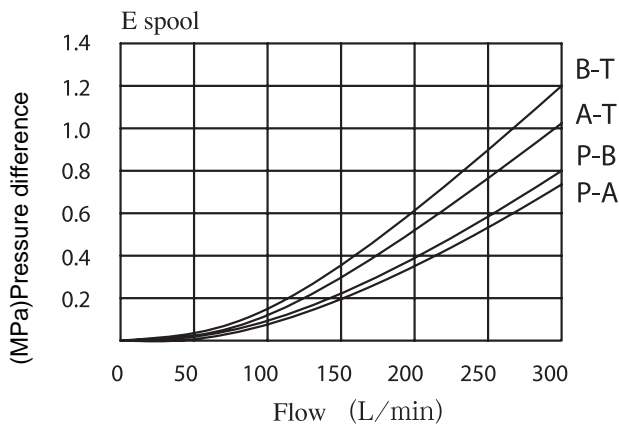

▶ Pressure drop vs. flow curves

WEH 25

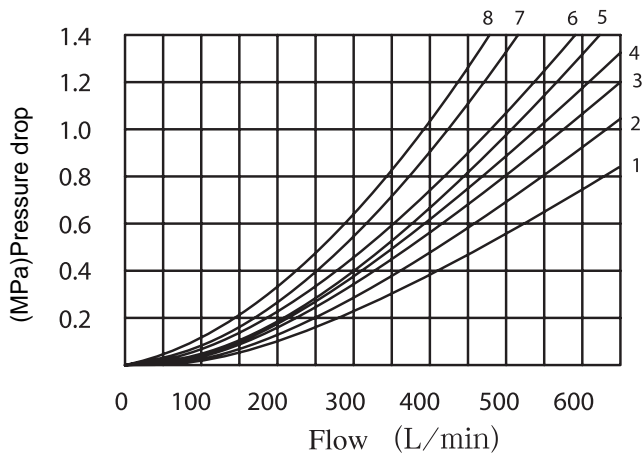

Point 7 is spool on the middle position, flow P-T

Point 8 is spool on the middle position, flow P-T

Spool symbols	Flow direction			
	P-A	P-B	A-T	B-T
E	1	1	1	3
F	1	4	3	3
G	3	1	2	4
H	4	4	3	4
J	2	2	3	5
L	2	2	3	3
M	4	4	1	4
P	4	1	1	5
Q	2	2	3	5
R	2	1	1	
U	2	1	1	6
V	4	4	3	6
W	1	1	1	3
T	3	1	2	4

▶ Pressure drop vs. flow curves

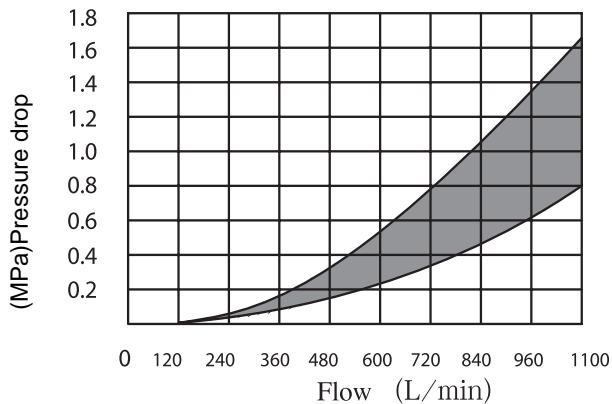
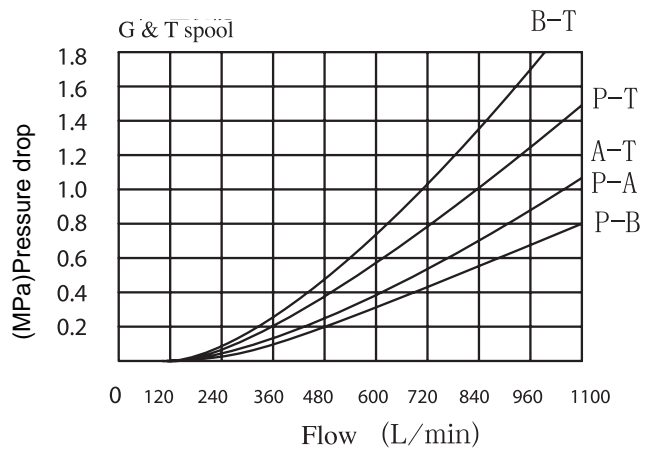
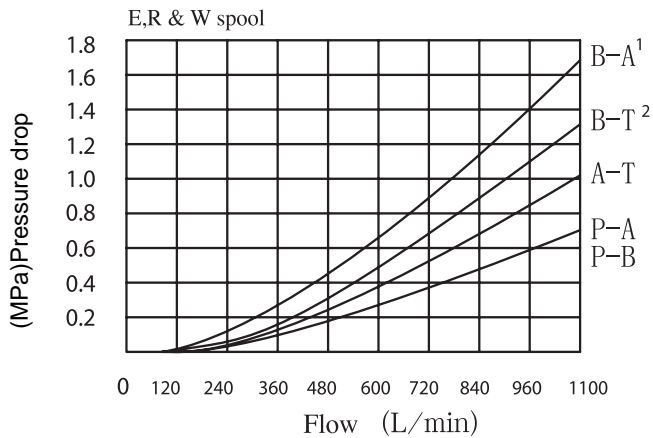

1 only for R spool

2 not for R spool

 Installation dimensions

WEH 10

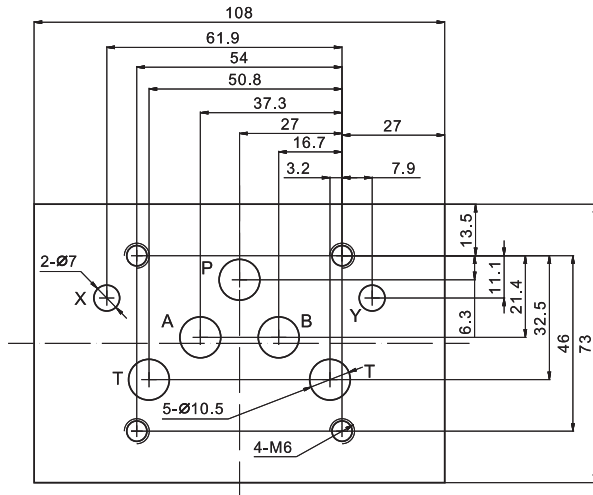

WEH 16

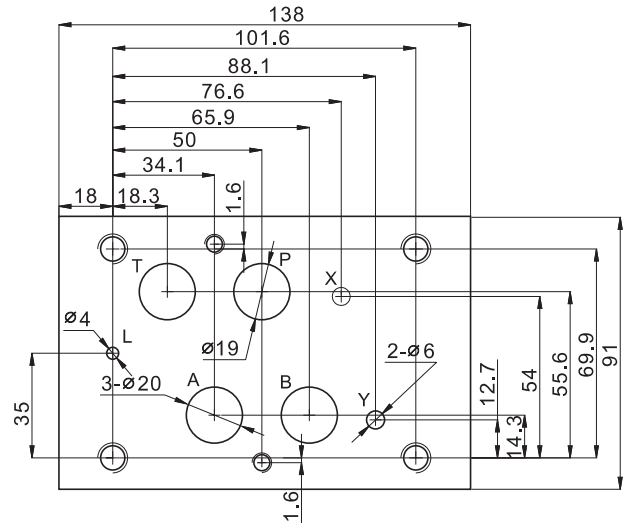

WEH 25

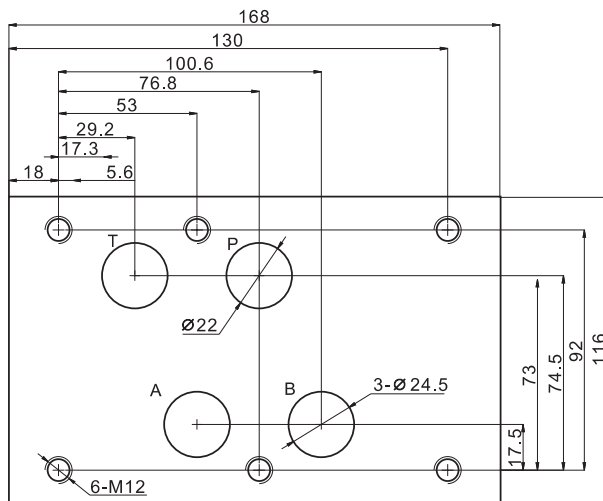

WEH 32

